

INVESTOR PRESENTATION

**stronger together**  
one global partner

MAY 8, 2024

# SAF-HOLLAND at a glance

## Company Profile

- SAF-HOLLAND is **one of the world leaders**, manufacturing **chassis-related assemblies and components**, primarily for **trailers, semi-trailers** as well as for **trucks and buses**
- Offering includes **axle and suspension systems** for trailers, **fifth wheels and coupling systems** for trucks, trailers and semi-trailers as well as **braking and electronic braking systems** plus **solutions for “Smart Trailers”**
- SAF-HOLLAND has a **global production footprint** with a **local-for-local approach** and c. **12,000 spare parts & service stations**

## Brands

SAF

Holland

Haldex

K/L

NEWAY

V.ORLANDI

YORK

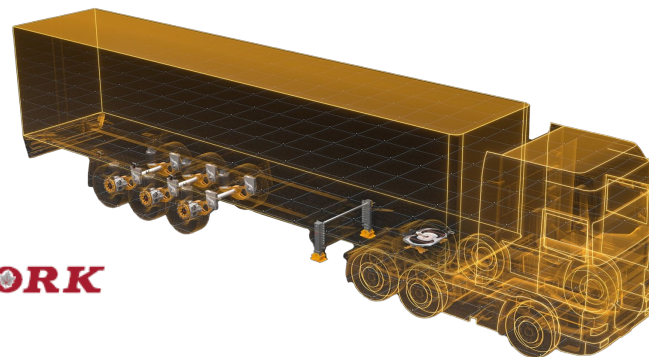

## Numbers

- SAF-HOLLAND employs **~6,000 people** on six continents
- **FY 2023 sales** were **EUR 2.11 bn** and **adj. EBIT margin 9.6%** or **EUR 202 mn**

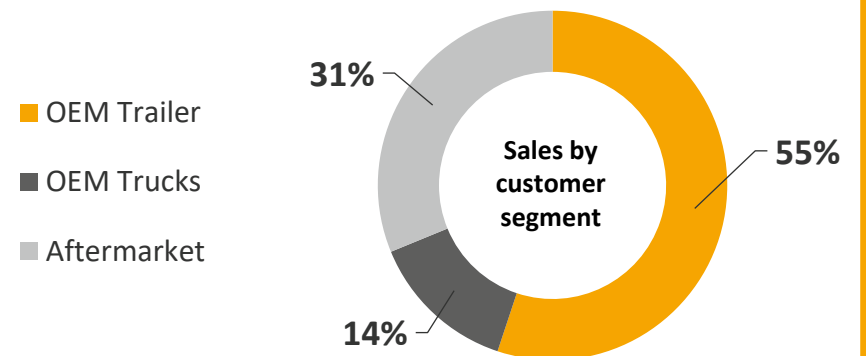
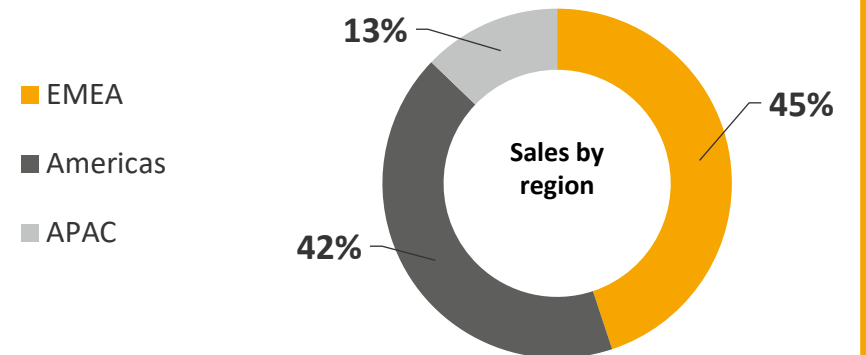

# Business model and financial overview





## OUR VISION

We want to be the most trusted and reliable partner in the commercial vehicle industry.

# A compelling case: SAF-HOLLAND investment highlights

---

**1** SAF-HOLLAND strongly positioned to benefit from **global road freight volume which is expected to almost triple** until FY 2050, creating **further need for transportation equipment**

**2** **Industry megatrends** such as digitalization, electrification, autonomous driving and safety addressed by SAF-HOLLAND's **comprehensive product and solution portfolio**

**3** SAF-HOLLAND with **strong market position** based on **one-stop-shop offering**, incl. **local-for-local approach** and **direct access to fleet customers**

**4** **Resilient and highly profitable aftermarket** sales streams of around one third of Group sales, **supporting Group adj. EBIT significantly**

# Attractive financial framework of SAF-HOLLAND

## Resilient aftermarket share

Around **one third of Group sales** is based on resilient and highly profitable aftermarket business

## Robust sales and margin targets for FY 2027

Group sales of **EUR 2.4 to 2.5 bn** resp. an **organic sales CAGR of 3.9%\*** compared to FY 2023 in combination with an **adj. EBIT margin of 9.0 to 9.5%**

## Asset and fixed cost light business model

Planning with stable **CAPEX ratio of up to 3%** of sales until FY 2027. **Low fixed cost structure with high double-digit material cost share of cost of sales** supports margin resilience

## Sustainable cash generation

Despite strong sales growth and Haldex acquisition, **NWC ratio of 14.1% of sales underlines FY 2027 target** of 15 to 16%

## Strong ROCE achievements

Rolling 8-quarter average **ROCE of 16.0%, above WACC**, creating constant shareholder value generation and **underlying FY 2027 target** of at least 15%

## Attractive dividend policy

Dividend policy: **Pay-out ratio of 40 to 50%** of available net income to shareholders

\* CAGR 2023-2027 calculated based on mid-point of FY 2027 target

# SAF-HOLLAND very well positioned to benefit from increasing transportation demand

Overarching demand driver: Global road freight demand set to almost triple to 844 bn kilometres until 2050\*

**Commercial Vehicle Industry Megatrends**

## Electrification

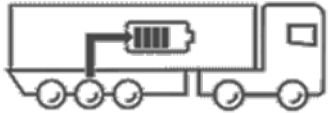

## Digitalization



## Automated Driving

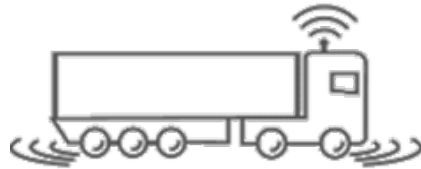

## Traffic Safety

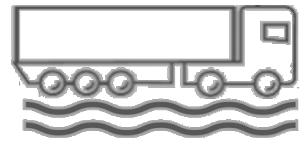

## Drivers

- CO<sub>2</sub> reduction
- Noise reduction
- Legislation

- Predictive maintenance
- Optimisation of uptime
- Increased efficiency
- Security increase

- CO<sub>2</sub> reduction
- Increased efficiency
- Driver shortage

- Brake regulation
- Long vehicle combinations
- Increasing road congestion
- Braking distances

## Offering

### Electrified axle solutions



### Digital trailer management



### Automated coupling



### Tire pressure monitoring





\* Source: OECD non-urban freight model in billion kilometers, Aug 2023



# Strong market access and product offering of SAF-HOLLAND plus Haldex

## Advantages from the Haldex acquisition

			
<b>MARKET ACCESS</b>			
Fleets	+	0	+
Small/Mid OEs	+	0	+
Big OEs	+	0	+
<b>PRODUCT CAPABILITIES</b>			
Brake & Chassis Control	-	+	+
E/E-Vehicle-Architect.	0	0	+
Axle & Suspension	+	-	+
Telematics solutions	+	0	+
Wheel Brake	0	+	+
Wheel Hub	+	-	+
Tire Pressure Monitoring	0	-	0

+ Competitive Advantage   
 0 Neutral competitive position   
 - Competitive Disadvantage

Development to + progressing

## Deeper insight into the combined Group

- **Acquisition of longstanding supplier Haldex** and inclusion in the scope of consolidation as of February 21, 2023
- The combined Group has a **strong position as a one-stop-shop product and solution provider**
- **Comprehensive product portfolio** consisting of axles & suspension systems, brake & chassis control and telematics
- The combined product portfolio allows for additional solutions such as predictive maintenance or smart functions (e.g., burglary protection, trailer temperature measurement etc.)
- **Strong advantage especially from air disc brake solutions by Haldex**, offering significant sales growth opportunities in both trailer and truck markets
- **Synergy targets from the acquisition** of EUR 10 to 12 mn in FY 2023 as well as EUR 20 to 35 mn in FY 2027
- **SAF-HOLLAND should benefit from cross-selling synergies** of c. EUR 40 mn in FY 2023 and up to EUR 200 mn in FY 2027 driven by access to an extended customer base

Note: Indicative competitive advantages



# Comprehensive high-quality product portfolio of SAF-HOLLAND plus Haldex

- SAF-HOLLAND
- Haldex

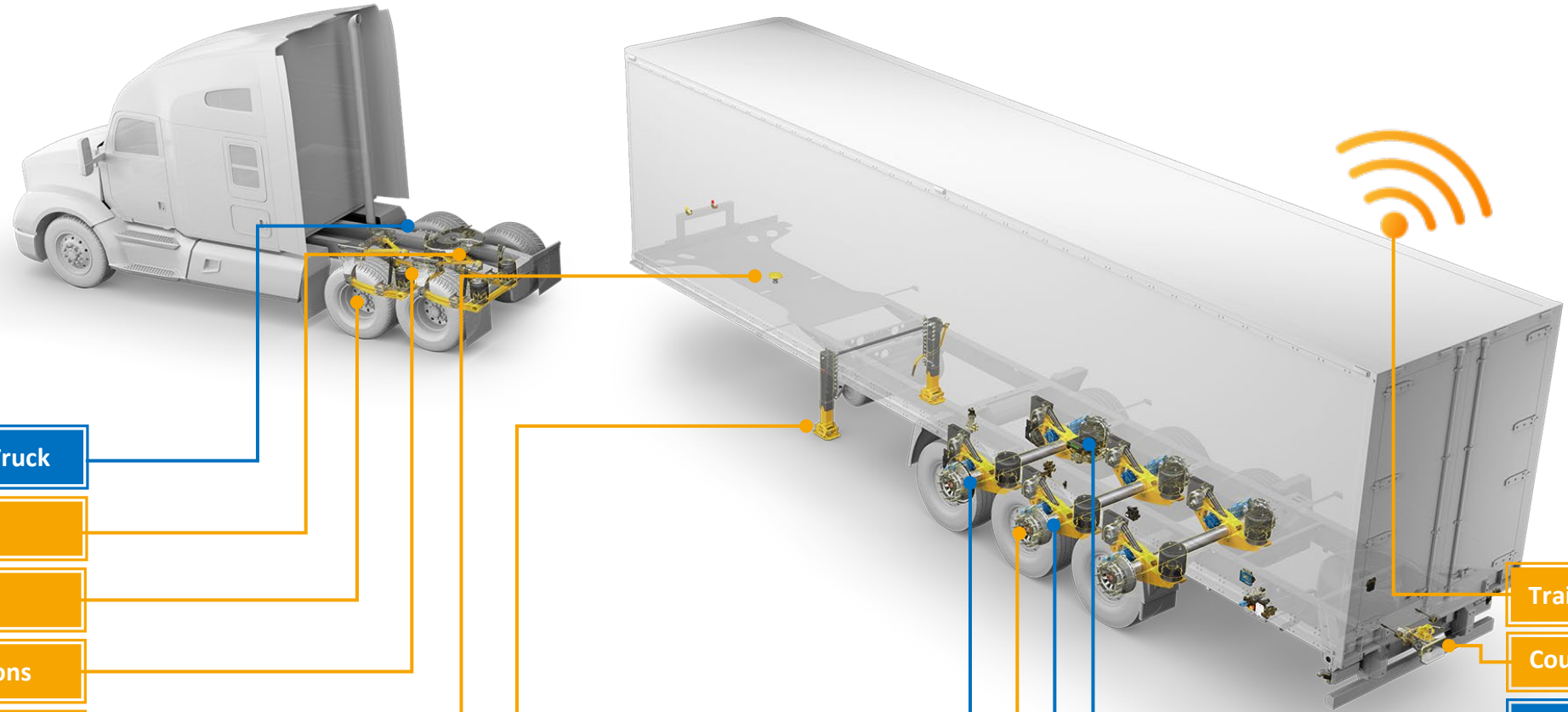

**Air Disc Brake Truck**

**Fifth wheels**

**Wheel systems**

**Truck suspensions**

**King Pins**

**Landing Gear**

**Actuators**

**Air Disc Brake Trailer**

**Brake Adjuster**

**Trailer management**

**Couplings**

**EBS and ABS**

**Air suspension**

**Axle- and suspension systems**

\* EBS: Electronic Brake System; ABS: Anti-Lock Braking System



# Significant customer benefits from increasingly integrated mechatronic offering



## One-stop shopping

- 1** **One contact** for **all chassis-related products** / systems
- 2** Solutions throughout the **entire product life cycle**: From initial consultation and configuration to delivery and Maintenance
- 3** **Single source provider** to help customers reduce the scope of supply chain and the dependence on external suppliers

Market Share Driver



## System integration

- 1** Harmonization and integration of mechatronics and axles / suspensions
- 2** Development of predictive Maintenance functions
- 3** Combination of Telematics and Trailer EBS\*

Structural Growth Driver

Sole system supplier worldwide for all chassis-related products

\* EBS: Electronic Brake System

# Leading positions in oligopolistic markets further enhanced by Haldex acquisition

	SAF-HOLLAND			Haldex	
	Trailer Axles	Fifth Wheels	Landing Gear	Suspension / Air Controls	Foundation Brake
					
<b>Global positioning</b>	#1-2	#2	#2	#1-3	
<b>Regional positioning</b>	#1 EMEA #1 India #3 NA*	#1 NA* #2 EMEA	#2 NA* #2 EMEA	#2 Europe: Air Disc Brakes, Trailer #1 Europe: Air Suspension, Trailer #3 Europe: Trailer EBS* #1 Europe / NA*: Brake Adjusters	



Top 3 positions across key products

\* NA: North America; EBS: Electronic Brake System

Note: Data based on 2021 and 2022

# Local-for-local set-up covering developed and growth markets globally

## Production locations

- SAF-HOLLAND
- Haldex

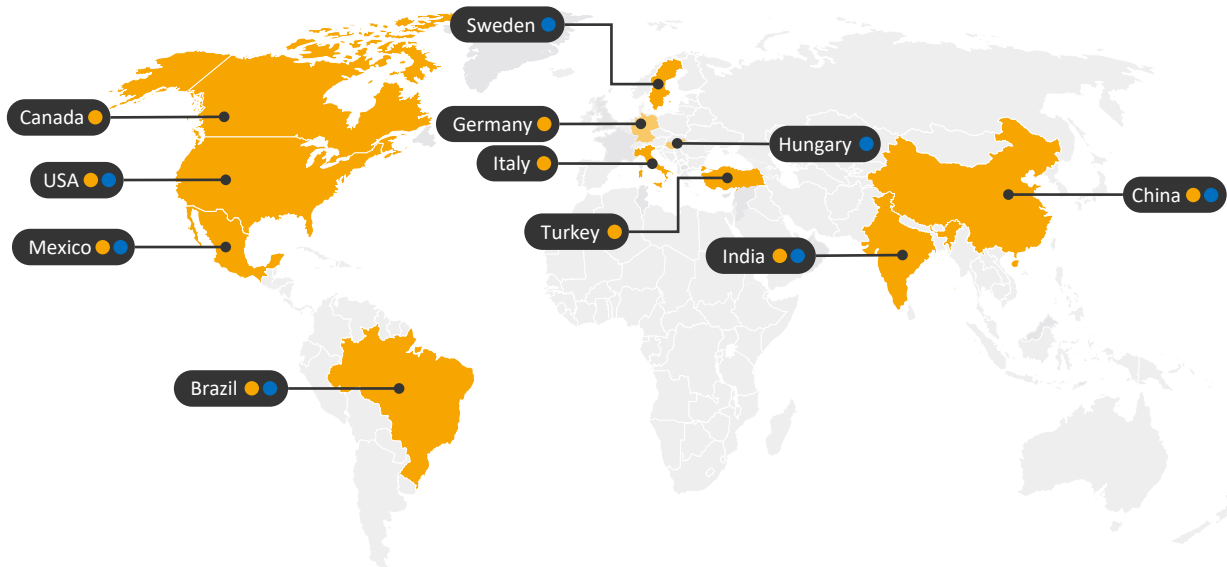

1

### Significant Benefits from Global Footprint...



Optimisation of distribution, sales and aftermarket network



Resilience: Differing regional market trends and replacement cycles



Superior product offering as a system supplier

2

### ... Plus Potential From Additional Growth Avenues



Rolling out EBS(\*) technology in North America and China



Pushing Air Disc Brake technology North America and China



Air suspension regulation in various regions

\* EBS: Electronic Brake System



# Direct access to broad and diversified end customer base: Fleet operators

- SAF-HOLLAND has long established relationships with fleet owners and trailer builders
- High brand recognition and superior product performance combined with unique aftermarket network
- Fleet managers specify SAF-HOLLAND products with trailer builders
- No dependency on single group of customers. ~70% of Group sales comes from diverse customer portfolio

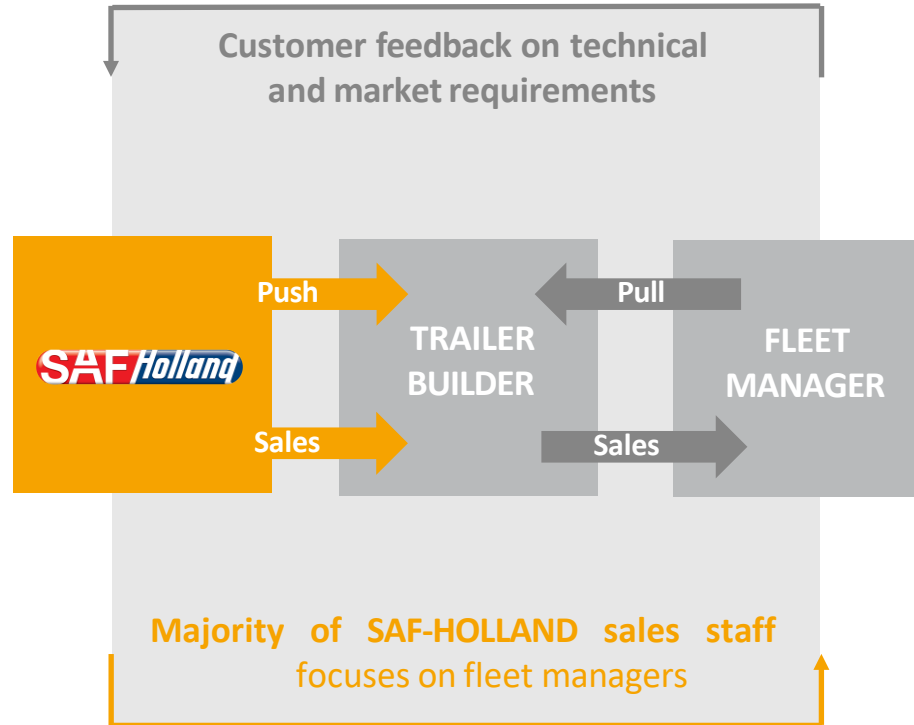

## Selected SAF-HOLLAND end customers



End customers choose SAF-HOLLAND because of lower total costs of ownership and higher efficiency over the life cycle

# Comprehensive aftermarket spare parts and service network worldwide

~12,000 spare parts dealers and service stations in more than 80 countries guarantee spare parts availability



SAF-HOLLAND axle population in EMEA has more than tripled

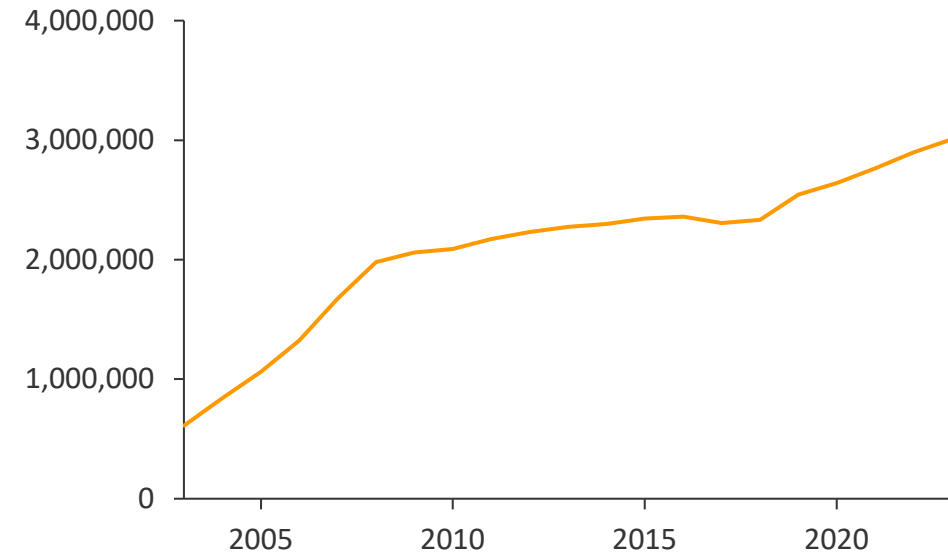



▶ Leading service network in Europe and North America:  
key asset for fleet customers and significant barrier to market entry

▶ Aftermarket business counter-balances potential volatility in OEM business and generates growth based on increasing product population in the field ("razor and blade business model")

# Digital aftermarket solutions ensure swift replacement of required Parts

## Ordering spare parts via QR-Code

- As of 2013, all axles delivered have a QR code on the type plate
- Since 2014, this has also applied to fifth wheels and landing gear
- The serial number is the key information required to identify replacement parts
- Via the QR code customers are directed to an online platform where they can directly order required spare parts

SAF-HOLLAND GMBH D-63856 BESSENBACH · GERMANY		SAF Holland	
Version	B9-22S	ID1 – SBS2243 – 10°	
Serial No.	13 12 125 0328	ID2 – SBS2220 H0	
Ident No.	347 91 68 7 49 01	ID3 – 10006	
Stat. 9000 kg Vmax. 105 km/h		ID4 – TDB0843	
Made in Germany	E	 SN 13121250328	

## Ordering spare parts via NFC

- From May 2023, all axles with compact bearings are fitted with an NFC chip in the hub cap
- With an NFC-enabled smartphone and the SAF-HOLLAND "SH-Connect" app product-specific spare parts and technical documentation is available and needed spare parts can be order online



# Aftermarket needs addressed from first to third owner of a vehicle

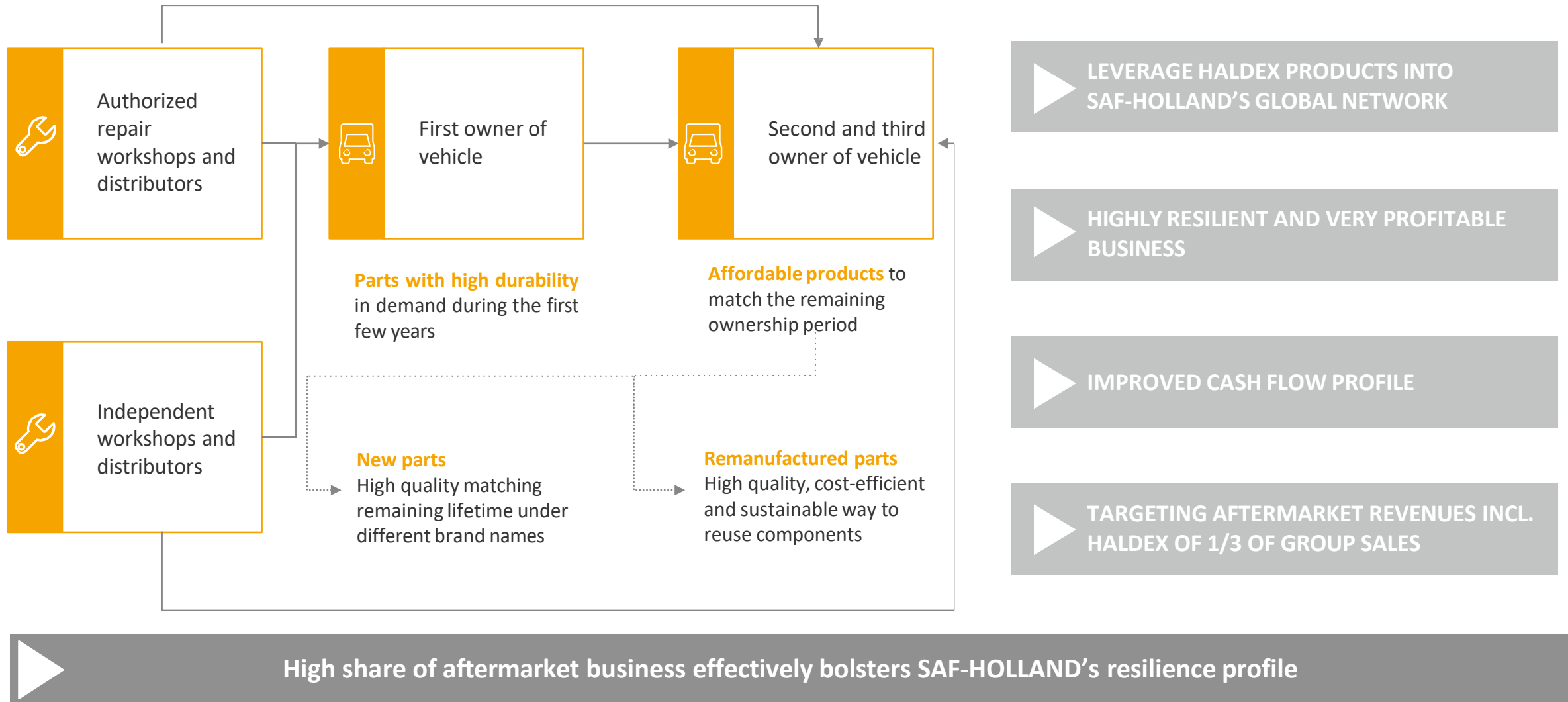



# Strong aftermarket exposure ensures resilient profitability

(EUR mn and %)

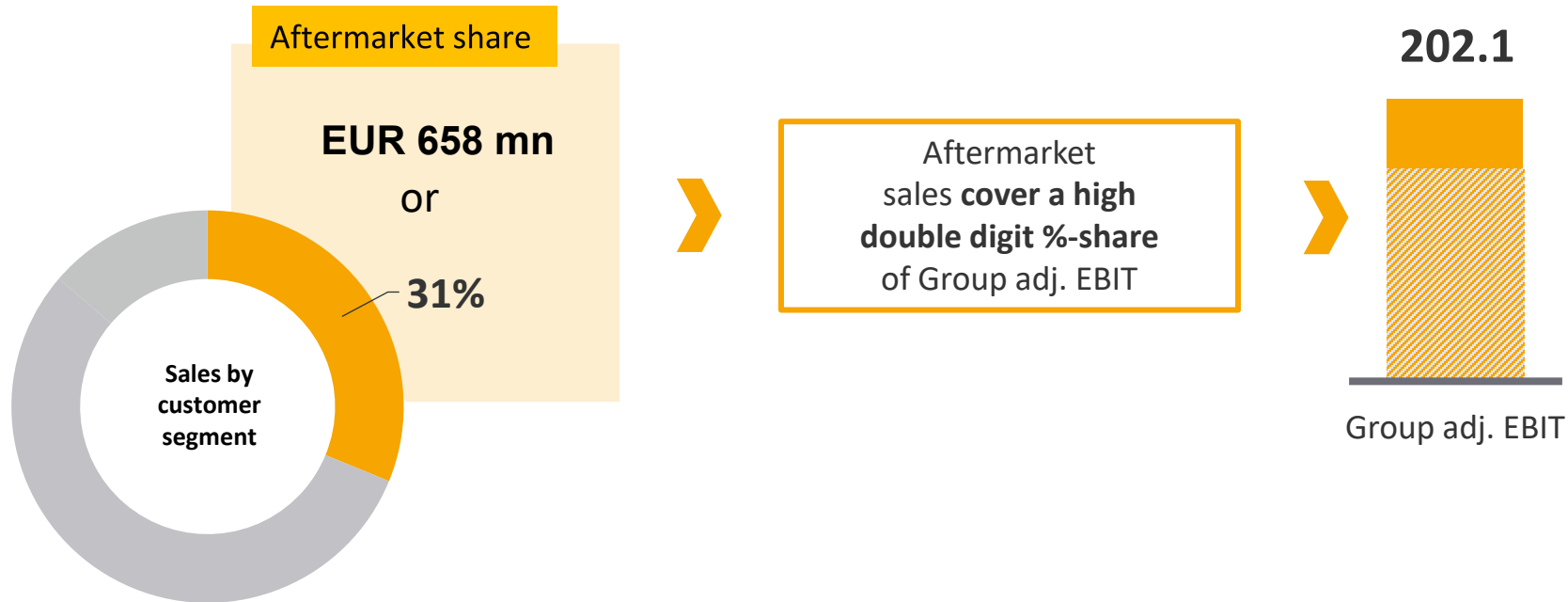

- Aftermarket sales streams are **resilient and highly profitable**
- **Strong aftermarket position** due to 12,000 spare parts & service stations, previous strong OEM-business growth and consolidation of Haldex creates increased aftermarket opportunities

# SAF-HOLLAND targets through-the-cycle profitability of 9.0 – 9.5%

## Group sales (in EUR mn)

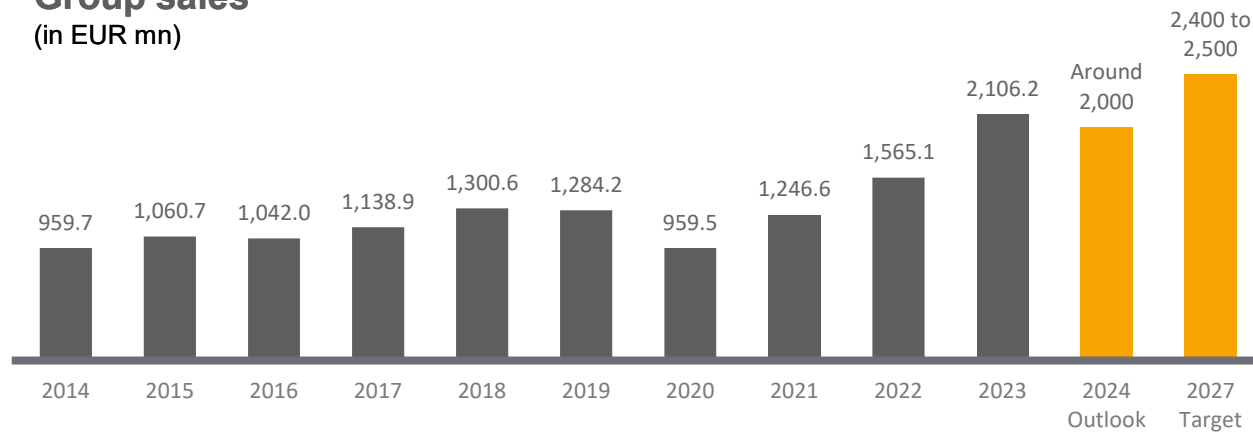

## Group adj. EBIT and adj. EBIT margin (in EUR mn and %)

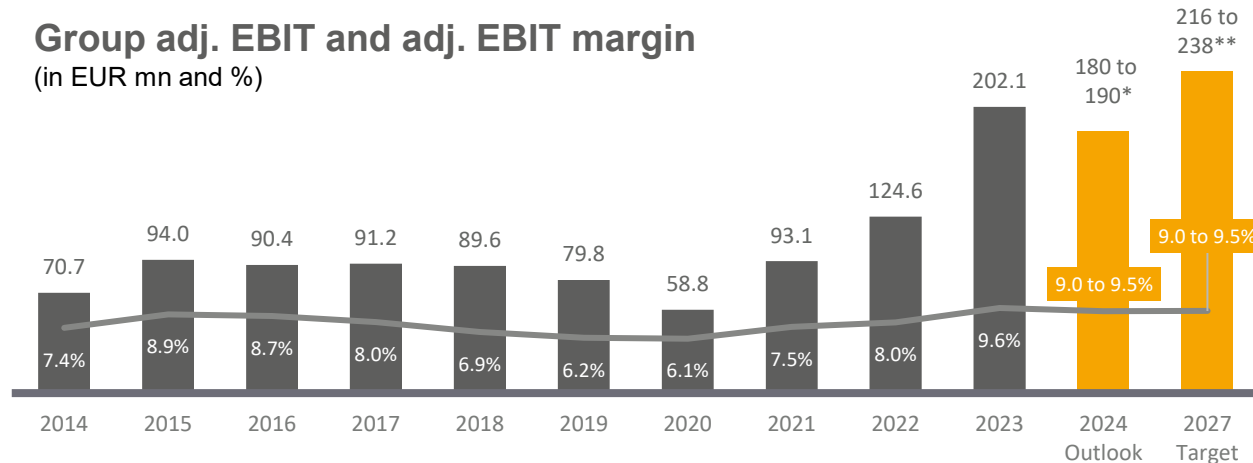

- **FY 2018 to FY 2020 adj. EBIT impacted** by reorganization of US factory footprint and supply chain disruptions, Chinese factory consolidation as well as COVID-19
- Despite a substantial sales decline of -25% in **FY 2020, adj. EBIT margin was resilient** and only slightly changed compared to FY 2019
- **Significant margin improvement from FY 2021 to FY 2023** despite supply chain disruptions as well as increased cost for material, energy and logistic as well as Haldex consolidation
- **FY 2024 outlook** is based on resilient business model and includes good profitability despite lower sales
- **FY 2027 target** implies an organic sales CAGR 2023 - 2027 of around 3.9%\*\*\* and a **through-the-cycle adj. EBIT margin of 9.0 to 9.5%**
- **Additional FY 2027 targets include:**
  - NWC ratio of 15 to 16%
  - ROCE of  $\geq 15\%$
  - Capex ratio of  $\leq 3\%$

\* Implied value calculated based on lower respectively upper end of target range of sales and adj. EBIT margin guidance

\*\* Implied value calculated based on lower respectively upper end of target range of adj. EBIT margin guidance and FY 2027 mid-point sales

\*\*\* Calculated with FY 2027 sales target at mid-point compared to FY 2023 sales

# No maturities outstanding before 2025, SAF-HOLLAND hedged against rising interests

## Maturity profile

(EUR mn)

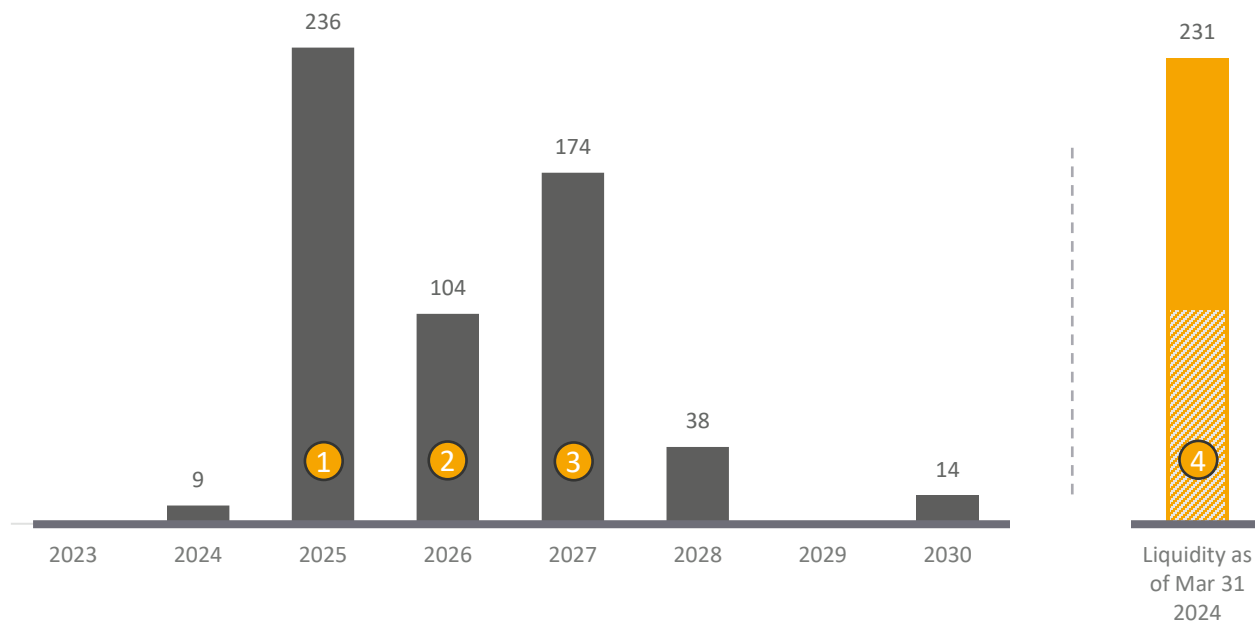

- ① Includes, amongst others, promissory notes of c. EUR 120mn and EUR 69mn each
- ② Includes various instruments from EUR 10 to 60 mn
- ③ Includes a term loan with a current amount of EUR 139 mn with a half-yearly regular repayment.

- **No substantial maturities** outstanding before FY 2025
- Slightly more than 70% of outstanding debt includes variable interest rates, **around 75% of these debt instruments are hedged against rising interest rates**
- Most of outstanding debt is related to the Haldex acquisition, was taken on balance end of FY 2022 and therefore already includes the elevated interest rate environment
- **Liquidity on balance** amounts to EUR 231 mn as of March 2024
  - ④ Targeting to make a substantial amount of liquidity available for either deleveraging, M&A activities or a share buyback via improved liquidity management
- In addition, a **revolving credit facility** of EUR 250 mn of which around EUR 35 mn was drawn at the end of March 2024, is available to SAF-HOLLAND

# Leverage remains almost stable at 1.9x

## Net debt/EBITDA

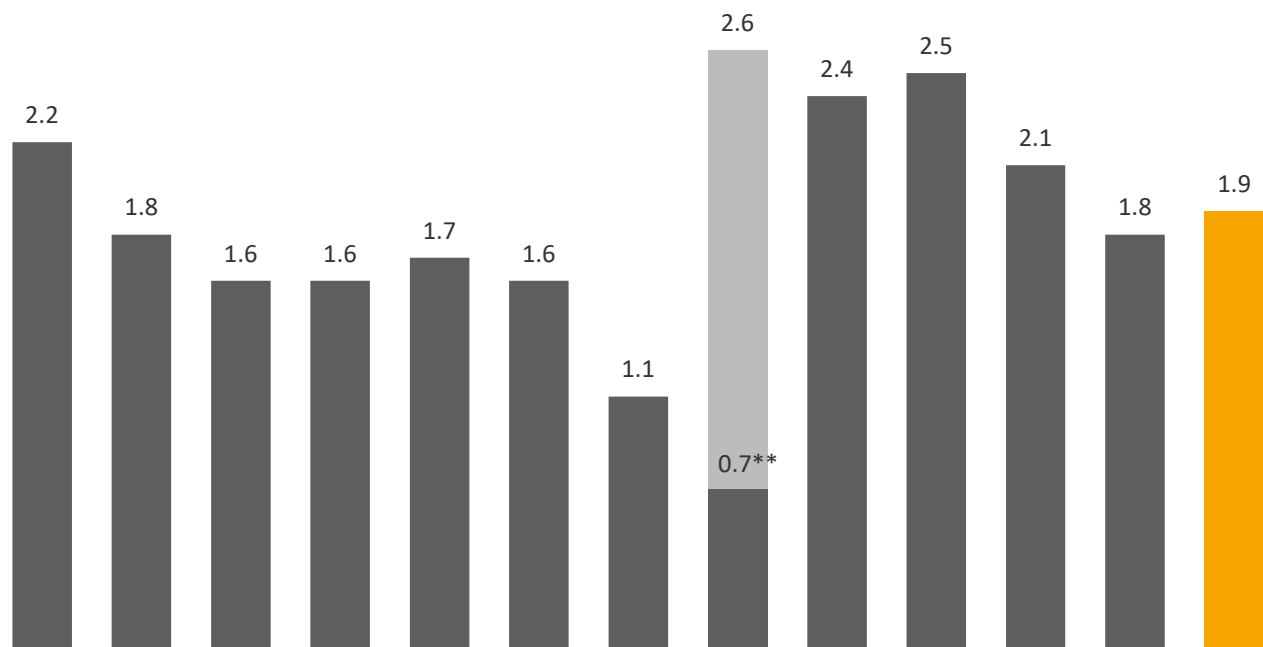

- Net debt/EBITDA ratio amounted to 1.9x at the end of Mar 2024, only slightly up from 1.8x at year-end 2023
- Increase in net debt mainly due to negative free cash flow
- Cash and cash equivalents were EUR 14.8 mn lower compared to 31 December 2023
- Slight increase of long-term interest-bearing loans and bonds (+EUR 15.6 mn)

EUR mn	Mar 2021	Jun 2021	Sep 2021	Dec 2021	Mar 2022	Jun 2022	Sep 2022	Dec 2022	Mar 2023	Jun 2023	Sep 2023	Dec 2023	Mar 2024
Net debt	195.6	200.4	200.7	198.0	210.3	206.4	158.8	108.4	508.1	536.5	475.4	450.2	482.4
EBITDA*	87.0	114.3	125.9	125.0	126.4	131.6	140.0	151.5	214.1	212.0	223.6	248.7	259.0

\* Reported EBITDA (LTM) \*\* Dec 2022 net debt/EBITDA ratio of 0.7x did not include additional debt to finance the acquisition of Haldex  
 Note: Net debt / EBITDA calculation includes Haldex related debt and pro-forma EBITDA (LTM) contribution for the periods Mar to Sep 2023.



# Key information about SAF-HOLLAND shares

## SAF-HOLLAND share price against SDAX

(January to May 2024, in EUR)

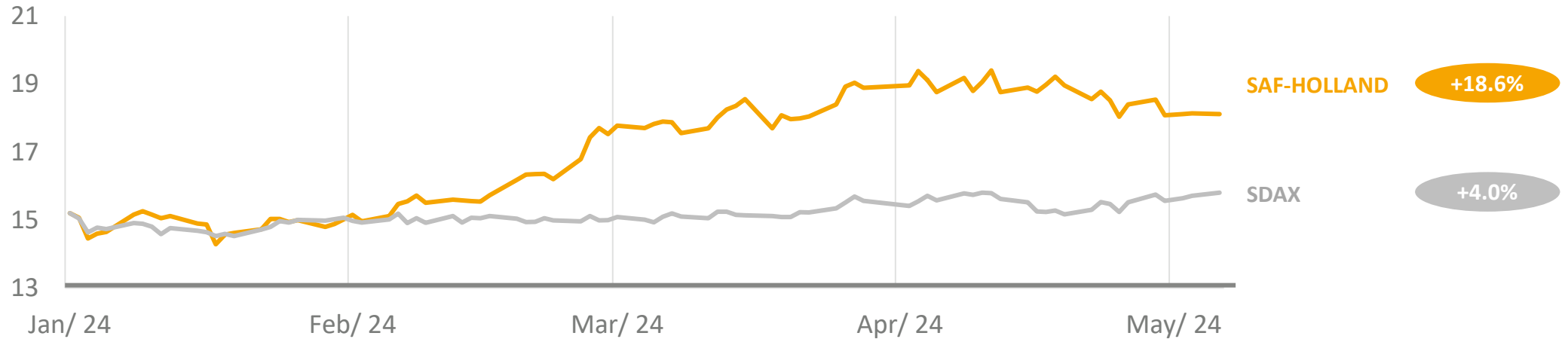

### Shareholder structure\*

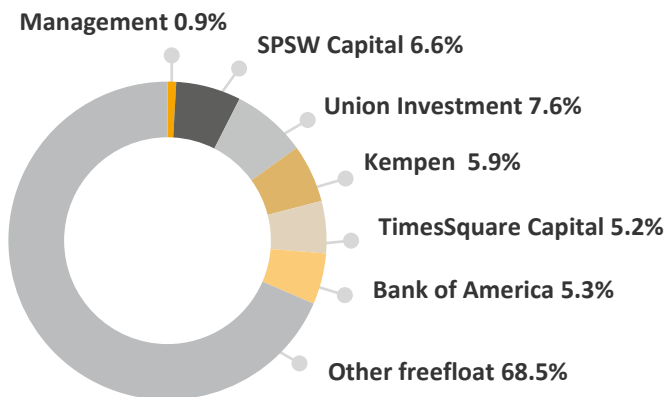

According to the definition of Deutsche Börse AG, 100% of the shares of SAF-HOLLAND SE are in free float



### Active analyst coverage

Berenberg	Yasmin Steilen
Deutsche Bank	Nicolai Kempf
DZ Bank	Holger Schmidt
Hauck Aufhäuser Lampe	Jorge Gonzalez Sadornil
Kepler Cheuvreux	Dr. Hans-Joachim Heimbuerger
Oddo BHF	Klaus Ringel
Warburg Research	Fabio Hoelscher

A summary of **continuously updated consensus estimates by an external source** can be found on the Investor Relations website under [Analysts](#)

\* Shareholder structure based on voting rights notifications and internal shareholder analysis

# Highlights and regional performance Q1 2024

# Q1 2024 Highlights



## M&A

**Full consolidation of IMS Group** as of January 2<sup>nd</sup> 2024; **Tecma closing** on April 2<sup>nd</sup> 2024

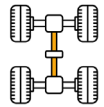

## Sales development

**Sales growth of +5.2% yoy** positively impacted by acquisition-related effects from Haldex and IMS Group counteracting declining OE markets in EMEA & North America



## Adj. EBIT margin

**Strong improvement in profitability from 9.0% of 9.6%** due to strict cost management as well as **favorable regional and customer segment mix**



## Cash flow & leverage

**Seasonal NWC built-up** impacted operating free cash flow which amounted to EUR -12.4 mn; **leverage of 1.9x** remains below 2024 target of 2.0x



## Outlook

**2024 outlook confirmed**

# SAF-HOLLAND with sustainable performance in softer market environment

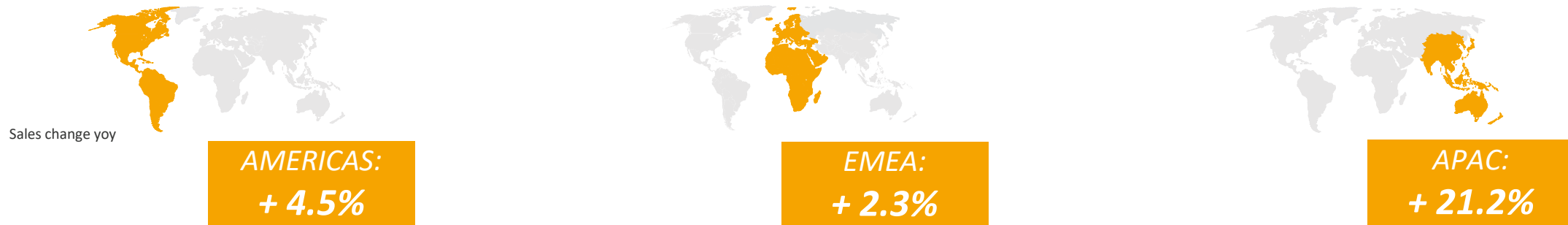

<p>Sales</p> <p><b>EUR 505.4 mn</b></p> <p>(Q1 2023: EUR 480.4 mn)</p>	<p>Adjusted EPS</p> <p><b>EUR 0.69</b></p> <p>(Q1 2023: EUR 0.54)</p>	<p>Adj. EBIT margin</p> <p><b>9.6%</b></p> <p>(Q1 2023: 9.0%)</p>	<p>NWC ratio</p> <p><b>16.5%</b></p> <p>(31 Dec. 2023: 14.1%)</p>	<p>Operating FCF</p> <p><b>EUR -12.4 mn</b></p> <p>(Q1 2023: EUR 5.4 mn)</p>
--	---	---	---	--

# SAF-HOLLAND off to a solid start into 2024

## Group sales

(in EUR mn)

● 2023  
● 2024

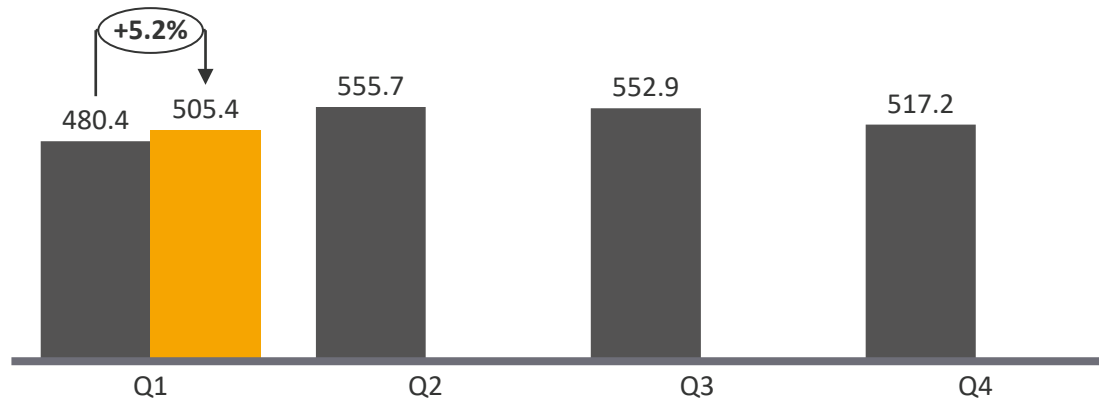
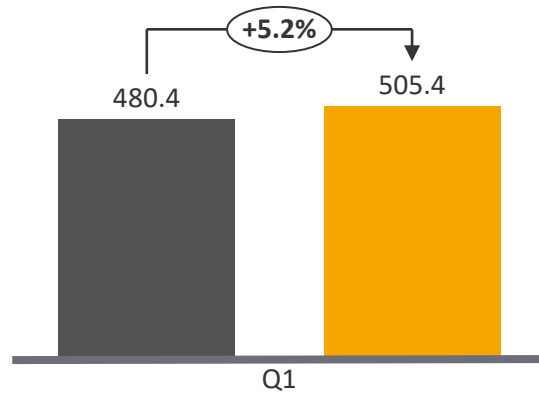

- Consolidation of Haldex (+7 weeks compared to Q1 2023) and IMS Group contributed EUR 66.1 mn to sales
- Weaker OE markets in EMEA and Americas cause an organic sales development of -8.1%, as expected
- APAC region with solid growth

# Increased share of aftermarket business driven by normalization of OE market

## Group sales split (by region, by customer category)

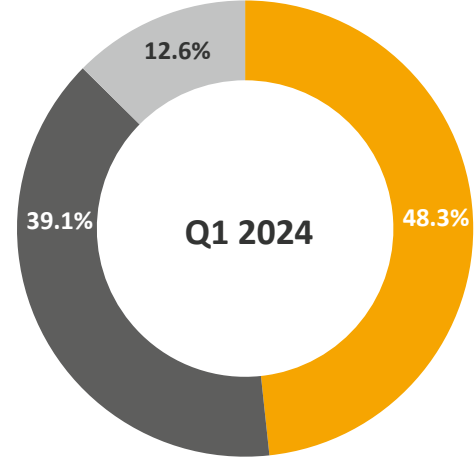
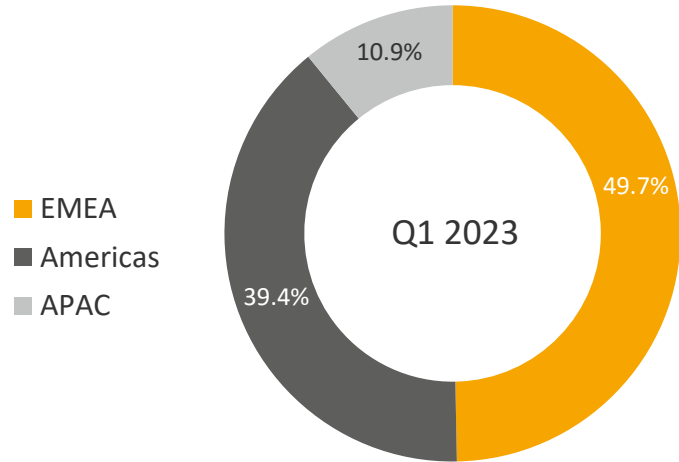

- Q1 2024 with opposing effects of weaker OE markets in EMEA and Americas but additional acquisition-related growth due to full contribution of Haldex as well as IMS Group (in EMEA)
- Share of Americas business impacted by softer trailer market
- APAC with continued solid growth

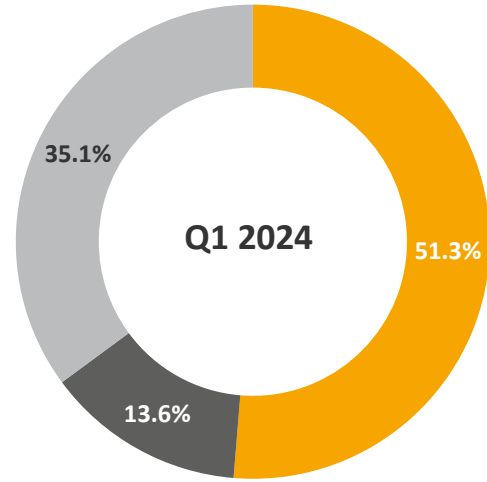
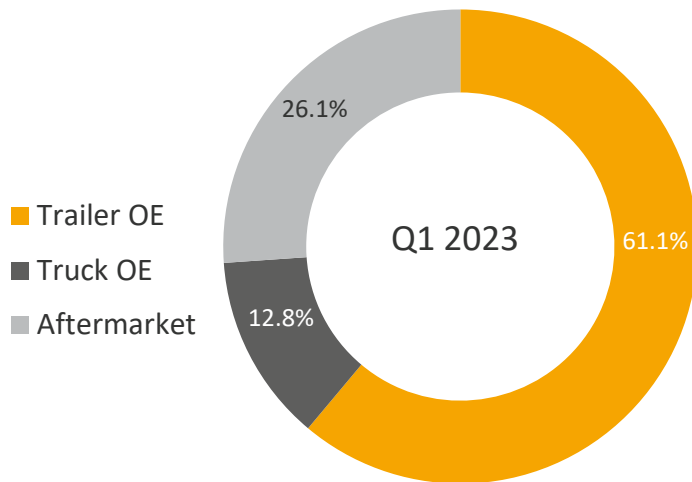

- Total OEM sales decreased by 7.6% to EUR 328.0 mn due to market normalization in EMEA and Americas
- Aftermarket business grew by 41.6% to EUR 177.5 mn in particular driven by full Haldex consolidation but also solid organic growth as a result of a growing OE population in previous years



# Strong profitability based on strict cost management, Haldex synergies and AM business

## Group adj. EBIT and margin

(in EUR mn and % of sales)

- 2023
- 2024

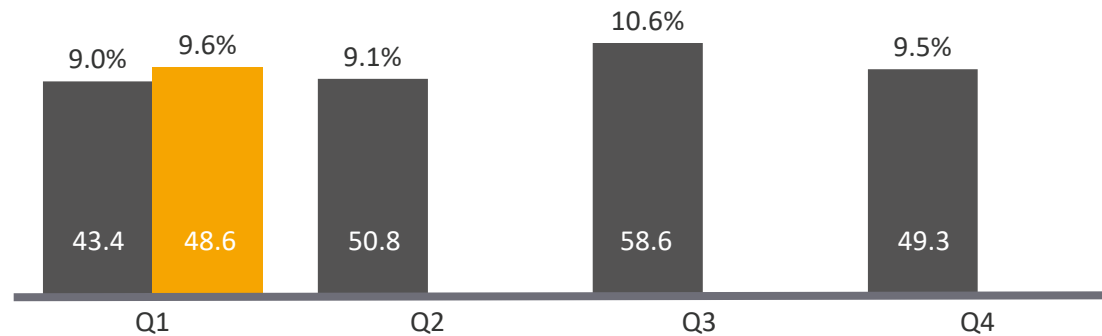
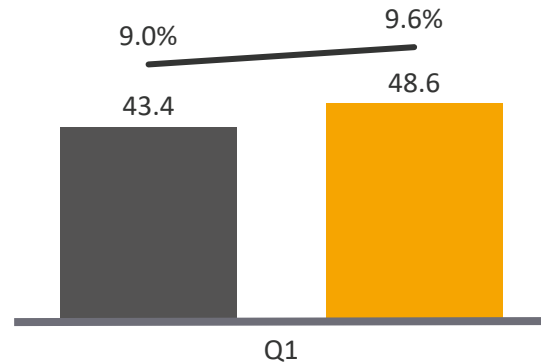

- Q1 2024 adj. EBIT rose by 12.0% to EUR 48.6 mn and resulted in an adj. EBIT margin of 9.6%
- Dampening effects on profitability from lower volumes in the OE business were more than compensated by
  - continued synergies from the Haldex integration, which were realized predominantly after Q1 2023
  - strict cost management, a favorable regional mix effect as well as a significantly higher aftermarket share

# Solid performance in EMEA due to Haldex and IMS Group acquisition

## EMEA sales

(in EUR mn)

- 2023
- 2024

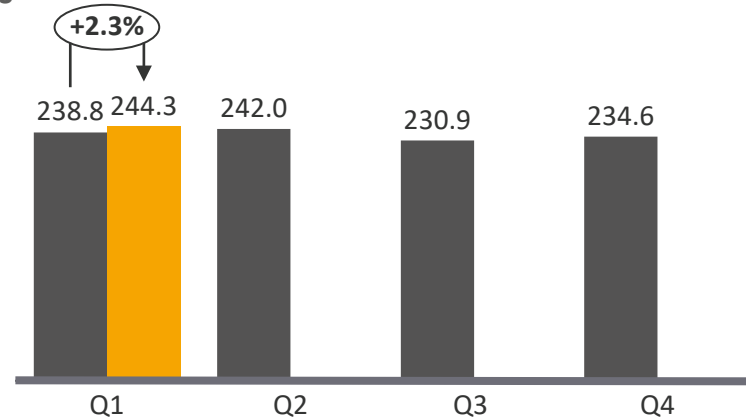

## EMEA adj. EBIT and margin

(in EUR mn and %)

- 2023
- 2024

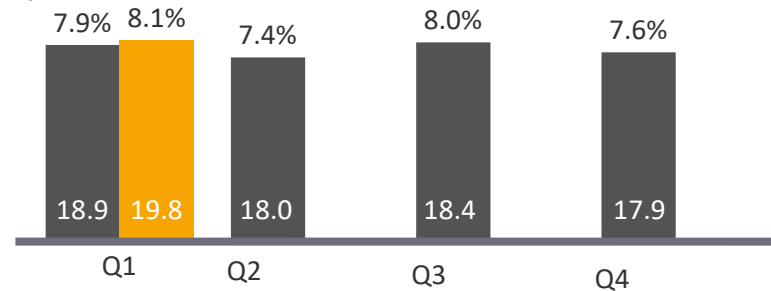

## Sales

- Q1 2024 organic sales growth amounted to -7.3%
- Newly acquired IMS Group contributed a mid single-digit euro million amount to sales
- Slight sequential organic growth of OE business compared to Q4 2023

## Adj. EBIT and margin

- Adj. EBIT grew by 5.0% to EUR 19.8 mn which resulted in an adj. EBIT margin of 8.1%
- Strict cost management as well as segment mix support favorable margin development
- Positive impact from acquisition-related synergy effects

# Americas region defies weaker market momentum and achieves strong adj. EBIT margin

## Americas sales

(in EUR mn)

- 2023
- 2024

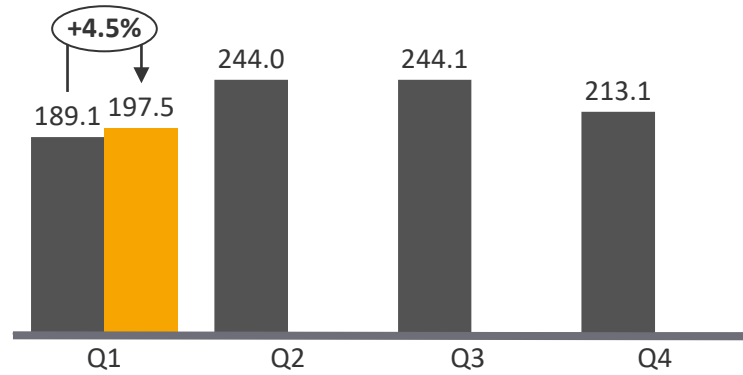

## Americas adj. EBIT and margin

(in EUR mn and %)

- 2023
- 2024

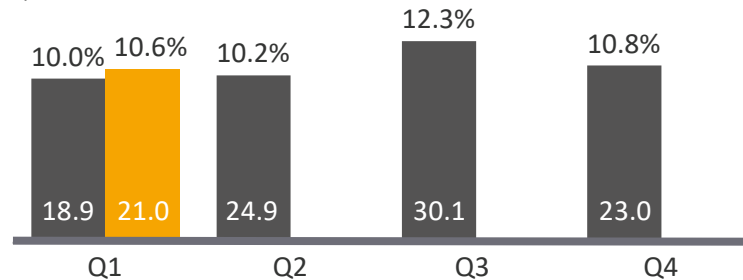

## Sales

- Q1 2024 with solid sales growth (including an organic sales growth of -15.5%) and a significant acquisition-related contribution from Haldex
- Organic sales development was muted due to softer customer demand for trailer and truck products in the US while aftermarket business was able to more than compensate for weaker OE dynamics
- Truck market with only slight declines while trailer market stronger impacted by ongoing normalization

## Adj. EBIT and margin

- Adj. EBIT increased strongly by 11.0% to EUR 21.0 mn and thus resulted in an improved margin of 10.6%, positively influenced by realized cost synergies from the Haldex takeover
- Sequentially compared to Q4 2023, capacity adjustments as well as a higher aftermarket share were able to compensate lower volumes

# Strong profitability development in APAC fueled by significant sales growth

## APAC sales

(in EUR mn)

- 2023
- 2024

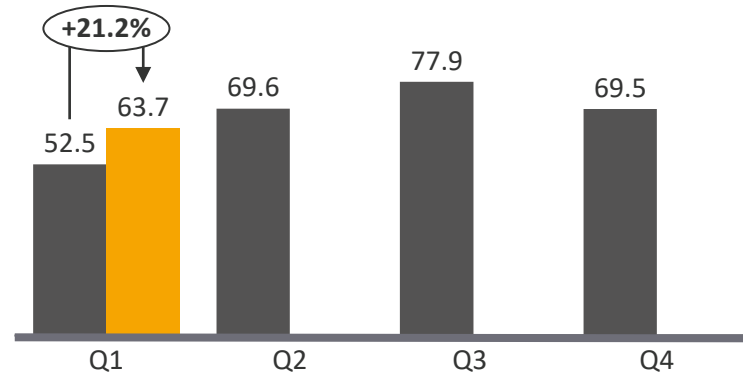

## APAC adj. EBIT and margin

(in EUR mn and %)

- 2023
- 2024

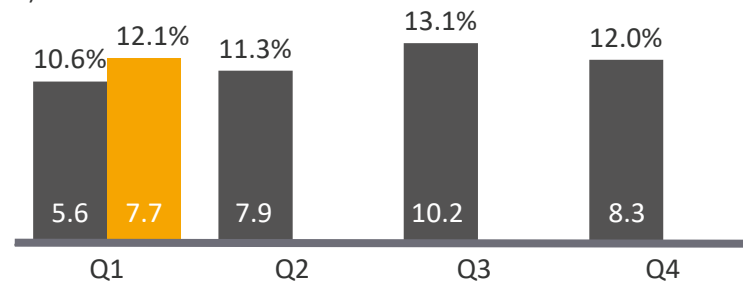

## Sales

- Q1 2024 organic sales growth amounted to 14.8% despite softer demand from North America which impacts the trailer production in APAC.
- Continued favorable market dynamics in India, Australia and China

## Adj. EBIT and margin

- Significant increase in adj. EBIT of 38.9% to EUR 7.7 mn mainly based on higher volumes
- Additionally, profitability benefited from a continued improvement in China

# Financials Q1 2024

# EBIT to adjusted EBIT reconciliation for the Group

in EUR mn	Q1 2024	Q1 2023	
<b>EBIT</b>	43.4	38.8	+11.8%
EBIT margin in %	8.6	8.1	
Additional depreciation and amortization from PPA <sup>①</sup>	5.2	2.3	
Valuation effects from call and put options	-	-	
Restructuring and transactions costs <sup>②</sup>	-	2.2	
Impairment on property, plant and equipment and intangible assets	-	-	
Other adjustments	-	-	
<b>Adj. EBIT</b>	<b>48.6</b>	<b>43.4</b>	+12.0%
Adj. EBIT margin in %	9.6	9.0	
<b>Adj. EBITDA</b>	<b>63.8</b>	<b>55.7</b>	+14.5%
Adj. EBITDA margin in %	12.6	11.1	

- ① Adjustments in Q1 2024 purely refer to PPA
- ② Q1 2023 was also impacted by restructuring and transaction costs of EUR 1.4 mn due to Haldex post-merger integration activities as well as EUR 0.4 mn related to the cyber attack



# Significant increase in adj. result for the period

(EUR mn and yoy change in %)

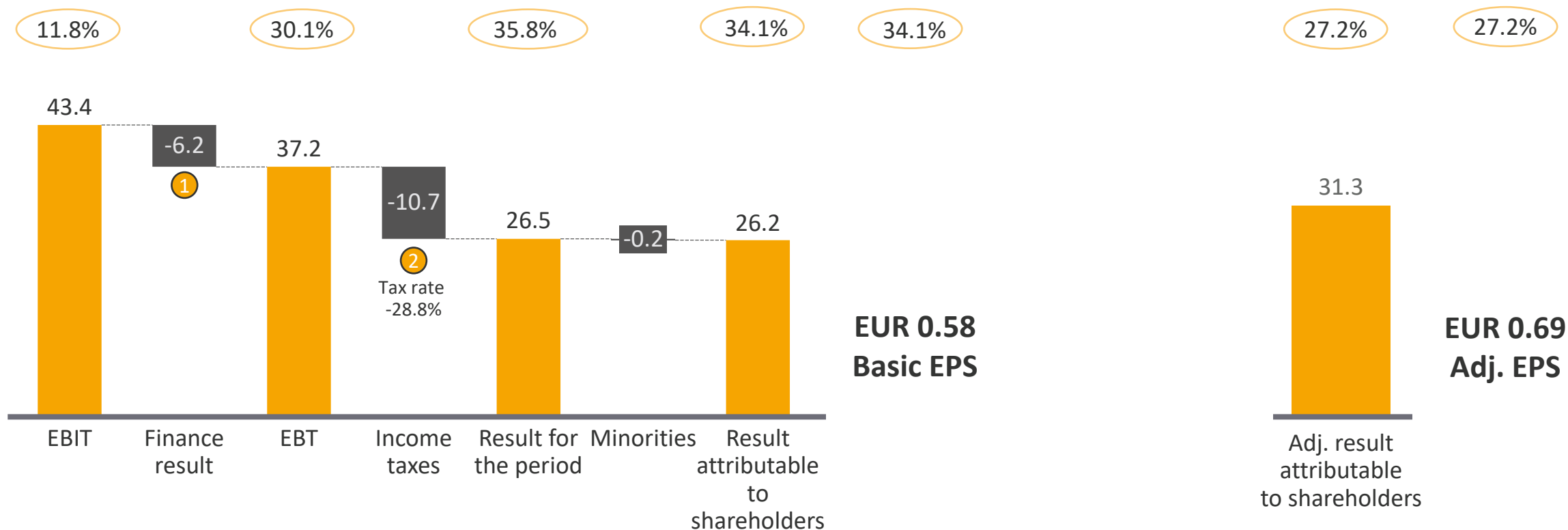

- ① Finance result improved from EUR -10.2 mn to EUR -6.2 mn mainly due to the valuation of intercompany foreign currency loans at the closing rate
- ② Q1 2024 tax rate of 28.8% driven by lower non-capitalized deferred tax assets on loss carryforwards at some subsidiaries (Q1 2023: 31.8%)

# Equity ratio continues to grow close to 30% range

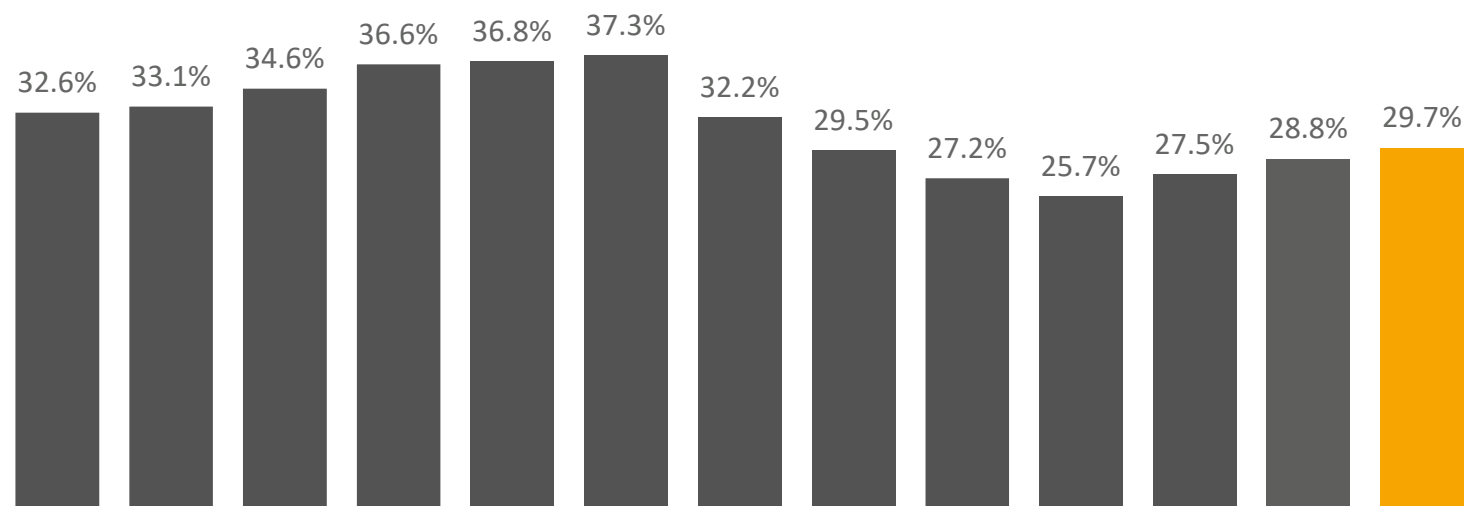

- Increase in equity by 5.5% compared to 31 December 2023 due to high result for the period
- Balance sheet total grew by 2.4% compared to 31 December 2023 primarily due to the acquisition of IMS Group
- Hence, equity ratio improved by 0.9%pts and came close to the 30% range

EUR mn	Mar 2021	Jun 2021	Sep 2021	Dec 2021	Mar 2022	Jun 2022	Sep 2022	Dec 2022	Mar 2023	Jun 2023	Sep 2023	Dec 2023	Mar 2024
Equity	325.2	334.8	353.7	371.1	390.5	431.1	468.5	441.4	449.8	433.4	468.8	476.0	502.3
Balance sheet total	998.6	1,010.4	1,022.9	1,014.3	1,060.4	1,156.4	1,456.9	1,498.4	1,650.7	1,686.9	1,706.5	1,651.7	1,691.2

# Seasonal increase in net working capital

Net working capital (in % of sales)

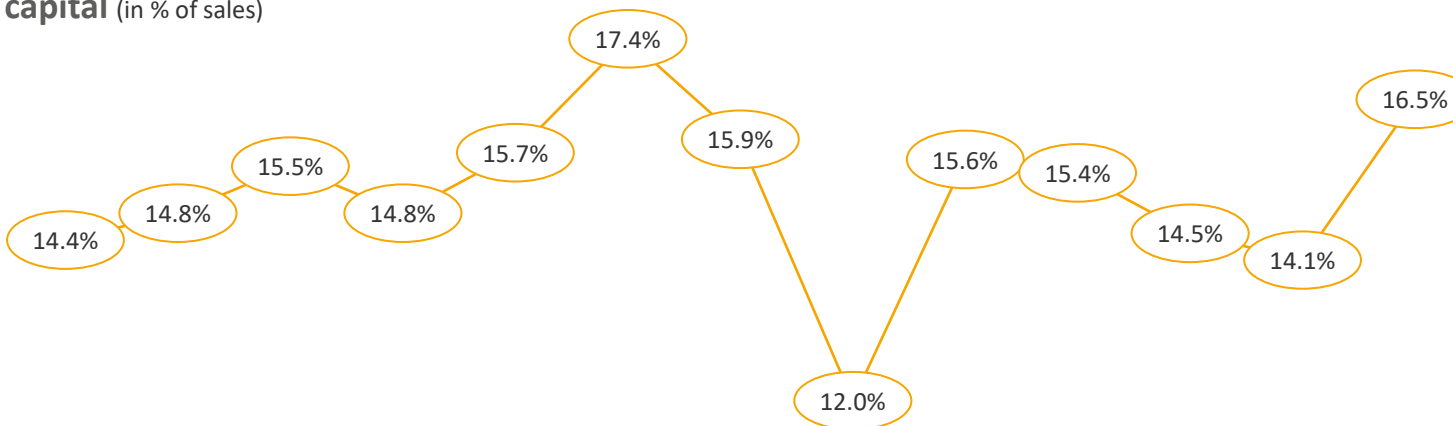

EUR mn	Mar 2021	Jun 2021	Sep 2021	Dec 2021	Mar 2022	Jun 2022	Sep 2022	Dec 2022	Mar 2023	Jun 2023*	Sep 2023*	Dec 2023	Mar 2024
Inventories	155.8	176.0	195.3	194.0	211.9	237.0	237.9	202.2	308.4	305.7	308.03	306.7	322.6
Trade receivables	130.0	148.9	147.2	136.3	176.1	184.6	187.0	144.7	283.0	286.4	253.2	219.7	256.6
Trade payables	-147.4	-163.4	-160.6	-145.8	-179.3	-176.2	-187.3	-159.0	-262.2	-261.4	-248.5	-228.6	-228.2
<b>NWC</b>	<b>138.4</b>	<b>161.5</b>	<b>181.9</b>	<b>184.4</b>	<b>208.7</b>	<b>245.5</b>	<b>237.6</b>	<b>188.0</b>	<b>329.2</b>	<b>330.7</b>	<b>313.0</b>	<b>297.8</b>	<b>350.9</b>
Sales (LTM)	961.7	1,091.4	1,175.6	1,246.6	1,330.7	1,411.7	1,497.5	1,565.1	2,112.8	2,143.2	2,165.1	2,106.2	2,135.7

Note: Since March 2023 data includes Haldex

\* Mar to Sep 2023 LTM sales include Haldex' contribution on a pro forma basis.

- NWC-ratio increased from 14.1% at year-end 2023 to 16.5%, showing a usual seasonal development in the first quarter of a year
- NWC grew by 17.7% compared to Dec 2023 in particular due to a reporting date related increase in trade receivables (+16.8%) as well as a delayed adjustment of inventories to the lower production volume (+5.1%)
- In addition, the consolidation of IMS Group led to an increase in NWC positions

# Swing in operating free cash flow mainly due to change in NWC

in EUR mn	Q1 2024	Q1 2023
<b>EBITDA</b>	<b>63.8</b>	<b>53.5</b>
Change in Net Working Capital	-43.6	-22.6
Taxes paid	-12.9	-7.5
Others	-14.2	-11.3
<b>Net CF from operating activities</b>	<b>-6.9</b>	<b>12.1</b>
Operating capex	-5.5	-6.7
<b>Operating free cash flow</b>	<b>-12.4</b>	<b>5.4</b>

- EBITDA increased due to early cost adjustments as well as favorable regional and customer segment mix
- Higher negative changes in NWC (EUR -21.0 mn) in particular impacted by change in trade receivables and trade payables; Q1 2023 figures were influenced by the cyber attack
- Paid income taxes grew strongly (+EUR 5.4 mn) due to higher earnings in previous periods
- Capex amounted to EUR 7.4 mn or 1.5% of Group sales
- Q1 2024 investments focused on further automation and modernization of production processes in EMEA and Americas

## Operating free cash flow\*

(in EUR mn)

- 2023
- 2024

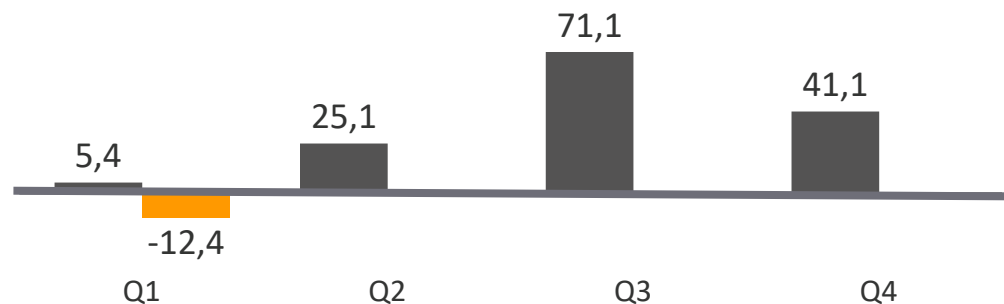

\* Pre acquisitions / acquisition of Haldex shares

# Remarkable ROCE level continues

Return on capital employed (in %)

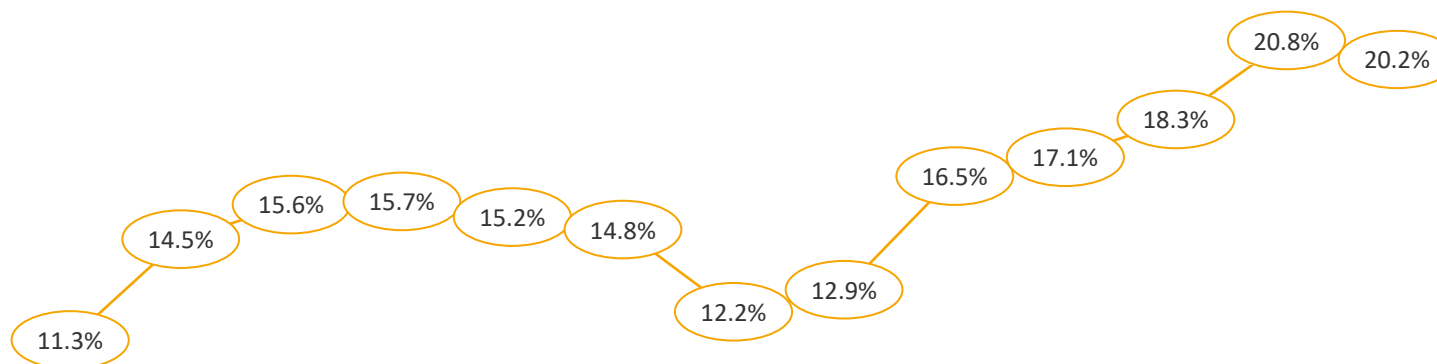

- ROCE amounted to 20.2% at the end of the first quarter, slightly decreased from high level at year-end 2023 predominantly due to the growth in equity as well as a moderate reduction in SAF-HOLLAND's cash position

EUR mn	Mar 2021	Jun 2021	Sep 2021	Dec 2021	Mar 2022	Jun 2022	Sep 2022	Dec 2022	Mar 2023*	Jun 2023*	Sep 2023*	Dec 2023	Mar 2024
Equity	325.2	334.8	353.7	371.1	390.5	431.1	468.5	441.4	449.8	433.4	468.8	476.0	502.3
Financial liabilities	332.4	323.7	318.5	322.2	318.9	369.9	614.5	715.7	663.3	683.8	663.6	628.7	647.4
Lease liabilities	42.7	41.6	41.7	41.1	40.4	40.9	39.9	38.4	62.7	68.0	67.4	67.8	66.5
Pension provisions	32.2	32.2	32.7	22.3	22.5	16.8	16.9	15.3	43.1	41.6	42.3	43.2	42.7
Cash/cash equivalents	-179.5	-164.9	-159.5	-165.2	-148.9	-173.0	-206.2	-243.5	-218.0	-215.3	-255.7	-246.3	-231.4
<b>Capital employed</b>	<b>553.0</b>	<b>567.4</b>	<b>587.1</b>	<b>591.4</b>	<b>623.4</b>	<b>685.7</b>	<b>933.7</b>	<b>967.3</b>	<b>1,000.9</b>	<b>1,011.5</b>	<b>986.5</b>	<b>969.3</b>	<b>1,027.4</b>
Adjusted EBIT (LTM)	62.3	82.1	91.5	93.1	94.7	101.8	114.1	124.6	165.0	172.6	180.3	202.1	207.3

\* For better comparability, Mar to Sep 2023 LTM adjusted EBIT includes Haldex' contribution on a pro forma basis.

# Outlook FY 2024 and key takeaways



# FY 2024 market outlook – Continued normalization in EMEA and Americas

	FY 2024e Trailer Market	FY 2024e Truck Market
EMEA	~ -15%	~ -15%
North America	~ -23%	~ -10%
Brazil	+/- 0%	~ +36%
China	~ +5%	~ +10%
India	~ +10%	~ -5%

## EMEA

- Based on an uncertain macroeconomic environment as well as on SAF-HOLLAND's current order situation, the European trailer market is expected to further normalize with a recovery expected in the second half of the year
- The European truck market expectations are unchanged

## North America

- Truck market expectations slightly improved compared to FY 2023 reporting
- Trailer market outlook almost unchanged

## Brazil

- Trailer market is expected to be flat while truck markets are expected to increase significantly in 2024

## China

- Both trailer and truck markets are expected to grow

## India

- Sharp increase in 2023 mainly based on public infrastructure investments and subsidies
- After parliamentary elections, more clarity on future development of Indian commercial vehicle market

## SAF-HOLLAND regional exposure by market segment

- EMEA
- North America
- Brazil
- China
- India
- Rest of APAC

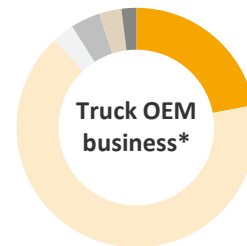

\* Indicative view based on FY 2023 sales

Note: Market forecasts are internal management assumptions based on customer communication, IHS Markit (Q1 2024), ACT Research (North America, April 2024), ANFAVEA (Brazil, Q4 2023)

# 2024 Outlook confirmed - robust profitability despite slightly lower sales

	Group FY 2023 Results*	Group FY 2024 Outlook
Sales	EUR 2,106.2 mn	Around EUR 2,000 mn
Adj. EBIT margin	9.6%	9.0% to 9.5%
Capex ratio**	2.9%	Up to 3%

\* Incl. Haldex contribution, consolidated as of February 21, 2023

\*\* Incl. payments for investments in property, plant and equipment and intangible assets as well as capitalized R&D

# Key takeaways

---

**1** **Solid start to 2024** based on full Haldex and IMS consolidation as well as **favorable mix effects** and **strict cost management**

**2** **Market normalization continues** as expected after several years with strong customer demand

**3** **Full Year 2024 guidance confirmed**, including a solid Q1 and upcoming project and wage costs expected from Q2 onwards

**4** **SAF-HOLLAND with resilient business model** well set up for softer 2024 market

# Contact and additional information

# Investor relations contact & financial calendar

## Issuer & contact

SAF-HOLLAND SE | Hauptstrasse 26 | 63856 Bessenbach

Dana Unger  
Vice President Investor Relations, Corporate & ESG Communications  
Tel: +49 6095 301 – 949

Alexander Pöschl  
Senior Manager Investor Relations, Corporate & ESG Communications  
Tel: +49 6095 301 – 117

Michael Schickling  
Senior Manager Investor Relations, Corporate & ESG Communications  
Tel: +49 6095 301 – 617

Marleen Prutky  
Junior Manager Investor Relations, Corporate & ESG Communications  
Tel: +49 6095 301 – 592

Email: [ir@safholland.de](mailto:ir@safholland.de)



## Financial calendar and road show activities

May 23, 2024	M.M.Warburg Conference, London
June 03 - 05, 2024	Berenberg Roadshow, North America
June 06, 2024	M.M.Warburg Conference, Hamburg
<b>June 11, 2024</b>	<b>Annual General Meeting</b>
<b>August 08, 2024</b>	<b>Publication of Half-Year Financial Report 2024</b>
September 04, 2024	Commerzbank & ODDO BHF Corporate Conference, Frankfurt
<b>November 12, 2024</b>	<b>Publication of the Quarterly Statement Q3 2024</b>

# Disclaimer

---

This presentation has been prepared by SAF-HOLLAND SE (“SAF-HOLLAND”) and comprises written materials concerning SAF-HOLLAND. It is furnished to you solely for your information and may not be reproduced or redistributed, in whole or in part, to any other person. It contains summary information only and does not purport to be comprehensive and is not intended to be (and should not be used as) the sole basis of any analysis or other evaluation of SAF-HOLLAND or its business. No representation or warranty, express or implied, is made as to, and no reliance should be placed on, the fairness, accuracy, completeness or correctness of any information, including projections, estimates, targets and opinions, contained herein, and no liability whatsoever is accepted as to any errors, omissions or misstatements contained herein, and, accordingly, neither SAF-HOLLAND nor any of the members of its management board or any of its officers, employees or advisors nor any other person shall have any responsibility or liability whatsoever (for negligence or otherwise) arising, directly or indirectly, from the use of this presentation, or its contents or otherwise in connection with this presentation.

This presentation contains certain statements related to our future business and financial performance and future events or developments involving SAF-HOLLAND and/or the industry in which SAF-HOLLAND operates that may constitute forward-looking statements. These statements may be identified by words such as “believes,” “expects,” “predicts,” “intends,” “projects,” “plans,” “estimates,” “aims,” “foresees,” “anticipates,” “targets,” and similar expressions. Forward-looking statements are not historical facts, but solely opinions, views and forecasts which are based on current expectations and certain assumptions of SAF-HOLLAND’s management or cited from third party sources which are uncertain and subject to risks. Actual events may differ significantly from the anticipated developments due to a number of factors, including without limitation, changes in general economic conditions, changes affecting the fair values of the assets held by SAF-HOLLAND and its subsidiaries, changes affecting interest rate levels, changes in competition levels, changes in laws and regulations, environmental damages, the potential impact of legal proceedings and actions and the Group’s ability to achieve operational synergies from past or future acquisitions. Should any of these risks or uncertainties materialise or should underlying expectations not occur or assumptions prove to be incorrect, actual results, performance or achievements of SAF-HOLLAND may (negatively or positively) vary materially from those described, explicitly or implicitly, in the relevant forward-looking statement.

The information contained in this presentation, including any forward-looking statements expressed herein, speaks only as of the date hereof and reflects current legislation and the current business and financial affairs of the SAF-HOLLAND which are subject to change and audit. Neither the delivery of this presentation nor any further discussions of SAF-HOLLAND with any of the recipients thereof shall, under any circumstances, create any implication that there has been no change in the affairs of SAF-HOLLAND since such date. Consequently, SAF-HOLLAND neither accepts any responsibility for the future accuracy of the information contained in this presentation, including any forward-looking statements expressed herein, nor assumes any obligation, to update or revise this information to reflect subsequent events or developments which differ from those anticipated.

This presentation is not directed to, or intended for distribution to or use by, any person or entity that is a citizen or resident or located in any state, country or other jurisdiction where such distribution, publication, availability or use would be contrary to law or regulation or which would require any registration or licensing within such jurisdiction. This presentation is for information purposes only and does neither constitute an offer to sell securities, nor any recommendation of, or solicitation of an offer to buy, any securities of SAF-HOLLAND in the United States, Germany or any other jurisdiction. In the United States, any securities may not be offered or sold absent registration or an exemption from registration under the U.S. Securities Act of 1933.

The information contained in this document has not been subject to any independent audit or review. Information derived from unaudited financial information should be read in conjunction with the relevant audited financial statements, including the notes thereto. Certain financial data included in the document consists of “non-IFRS financial measures”. These non-IFRS financial measures may not be comparable to similarly titled measures presented by other companies, nor should they be construed as an alternative to other financial measures determined in accordance with IFRS. You are cautioned not to place undue reliance on any non-IFRS financial measures and ratios included herein.